

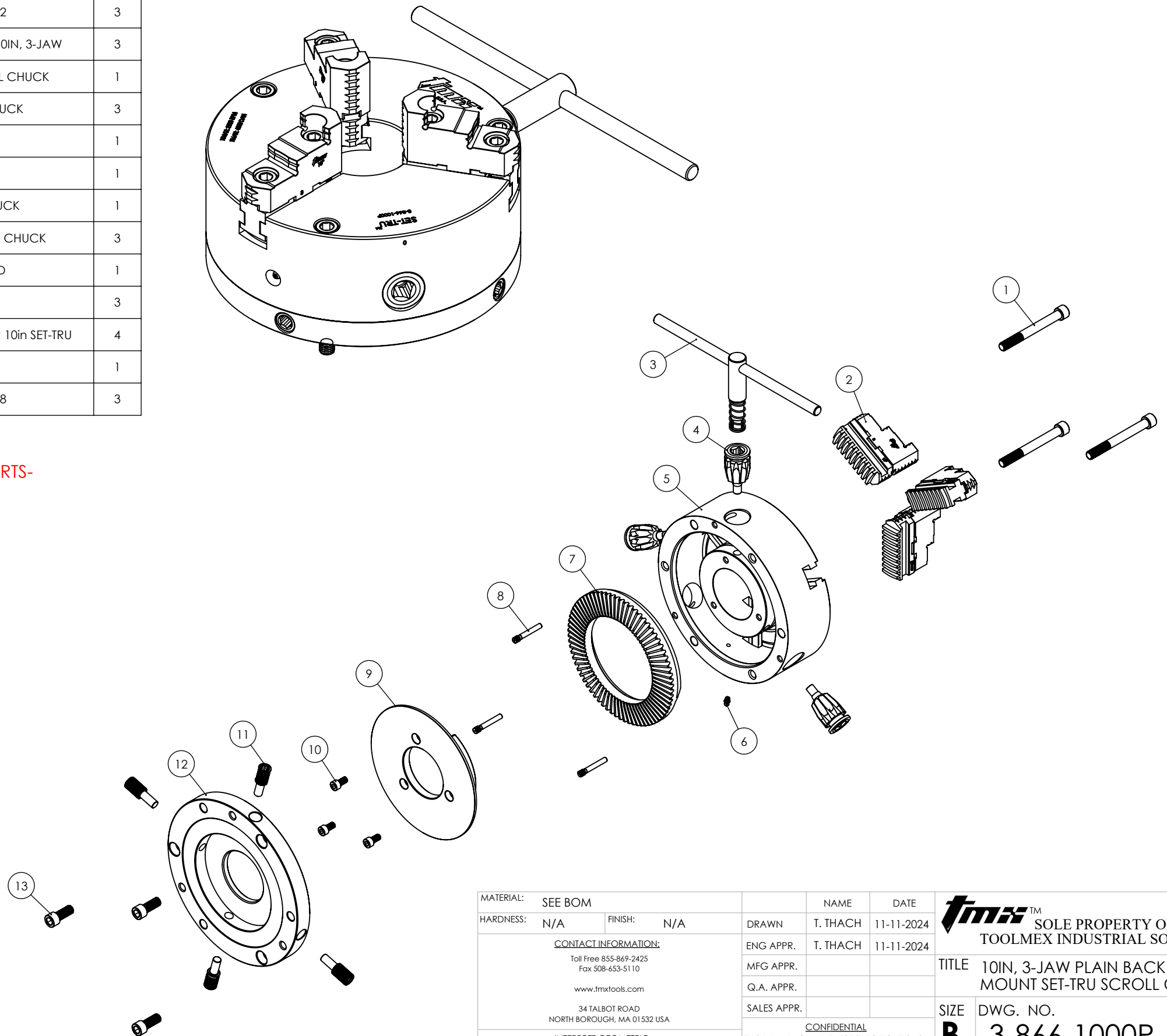

ITEM NO.	PART NUMBER	DESCRIPTION	QTY.
1	M12x1.75X110 SHCS	MCMaster P/N 91290A642	3
2	3-891-310P	FULL OEM JAW REPLACEMENT SET, 10IN, 3-JAW	3
3	3-889-012P	WRENCH FOR 10IN & 12IN SCROLL CHUCK	1
4	3-886-310P	PINION FOR 10IN SCROLL CHUCK	3
5	C-CK10-BDY3JFM	BODY, 10" SET-TRU	1
6	M6x1.0 GREASE FITTING	MCMaster P/N 1105K71	1
7	3-887-310P	SCROLL PLATE FOR 10IN CHUCK	1
8	3-888-910P	PINION SCREW FOR 8, 10 OR 12in CHUCK	3
9	C-CK10-COVER	PLATE, COVER, MACHINED	1
10	M8x1.25X16 SHCS	SHCS, M8x1.25X16	3
11	3-897-610P	FINE ADJUSTMENT SCREW, M18x1 FOR 10in SET-TRU	4
12	C-CK10-MODULE	MODULE, SET-TRU, 10IN	1
13	M12x1.75X30 SHCS	MCMaster P/N 91290A618	3

-CLICK ON LINK BELOW FOR REPLACEMENT PARTS-

WWW.TOOLMEX.COM

SELLING UNIT: EACH
 CHUCK TYPE: SET-TRU SCROLL
 CHUCK SIZE: 10IN
 BODY MATERIAL: FORGED STEEL
 NUMBER OF JAWS: 3
 JAW TYPE: 2 PIECES
 WEIGHT: 81 LBS
 MOUNT TYPE: FRONT
 GRIPPING FORCE: 4600 daN
 SPEED: 3500 RPM Max.



MATERIAL:	SEE BOM	NAME	DATE	 TOOLMEX™ SOLE PROPERTY OF TOOLMEX INDUSTRIAL SOLUTIONS	
HARDNESS:	N/A	FINISH:	N/A		
CONTACT INFORMATION: Toll Free 855-869-2425 Fax 508-653-5110 www.tmxtools.com 34 TALBOT ROAD NORTH BOROUGH, MA 01532 USA		DRAWN	T. THACH		11-11-2024
INTERPRET GEOMETRIC TOLERANCING PER: Y1999-2001		ENG APPR.	T. THACH		11-11-2024
 THIRD ANGLE PROJECTION		MFG APPR.			
		Q.A. APPR.			
		SALES APPR.			
		CONFIDENTIAL THIS DRAWING AND THESE SPECIFICATIONS ARE THE SOLE PROPERTY OF TOOLMEX INDUSTRIAL SOLUTIONS, AND SHALL NOT BE REPRODUCED, OR COPIED IN PART OR AS A WHOLE WITHOUT THE EXPRESS WRITTEN PERMISSION OF TOOLMEX INDUSTRIAL SOLUTIONS IS PROHIBITED.		TITLE 10IN, 3-JAW PLAIN BACK FRONT MOUNT SET-TRU SCROLL CHUCK	
		SIZE	DWG. NO.	REV	
		B	3-866-1000P	A	
		UNITS IN MILLIMETER			
		DO NOT SCALE DRAWING		SHEET 1 OF 3	

[8.8189]
Ø 224.00 B.C.

[9.8425]
Ø 250.00

[3.0000]
Ø 76.20

Toolmex
U.S.A.

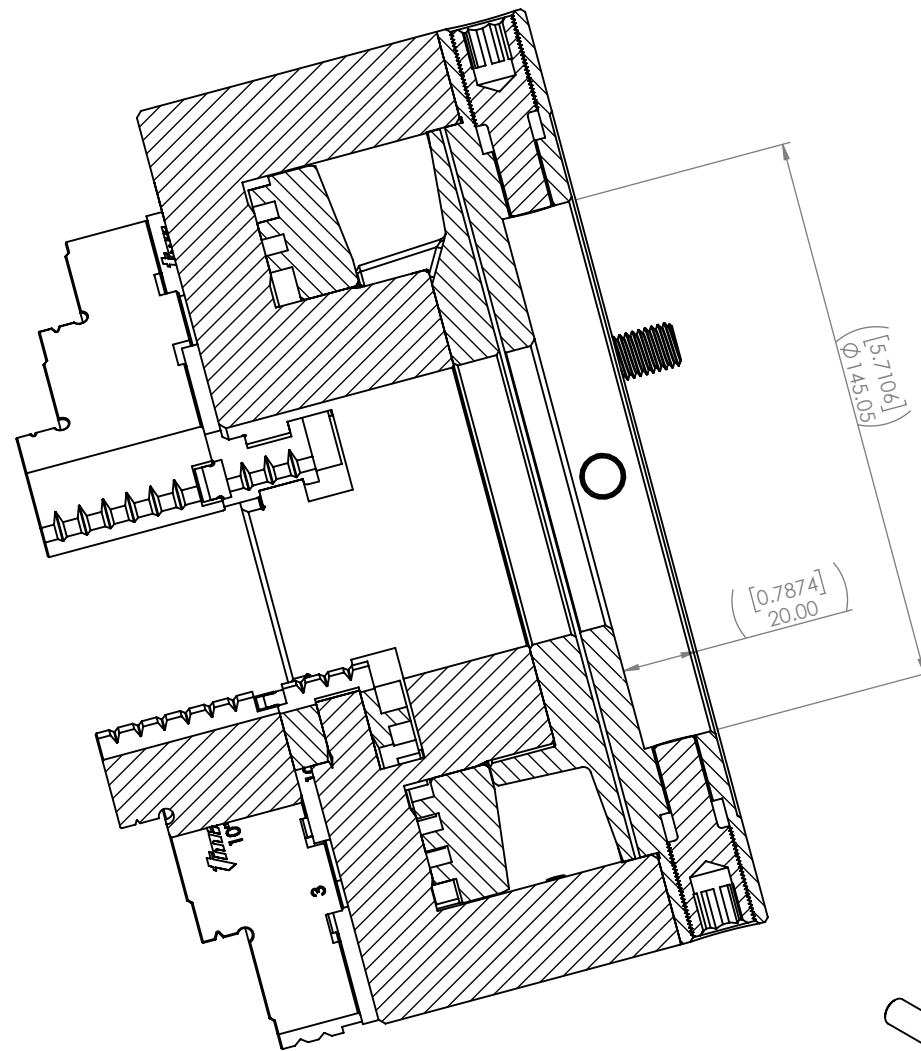

SET-TRU™
3-866-1000P

NEW YORK, NY
NEW JERSEY, NJ
NEW HAMPSHIRE, NH

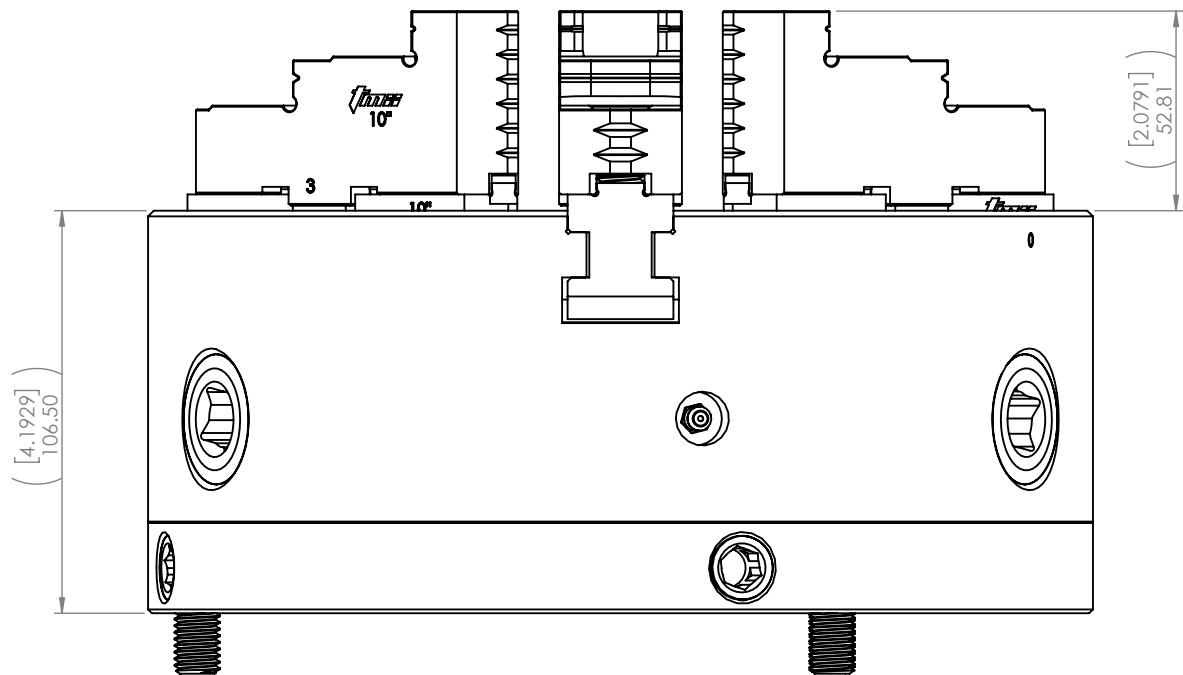
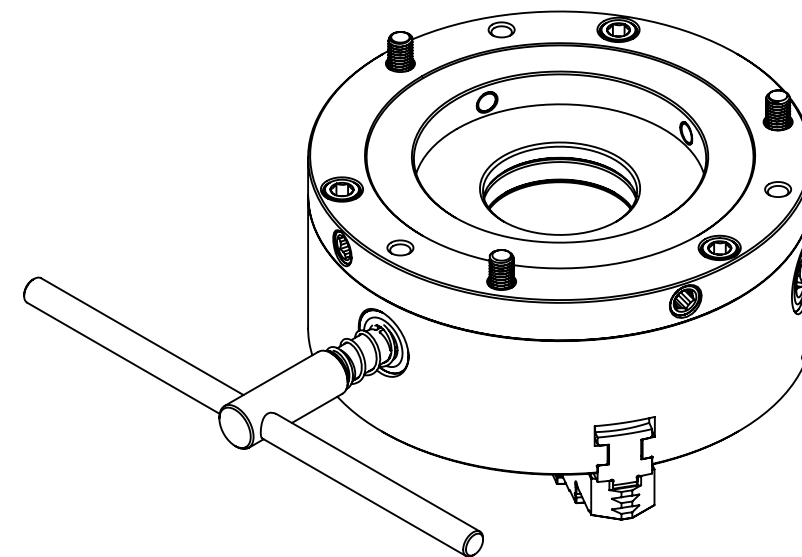
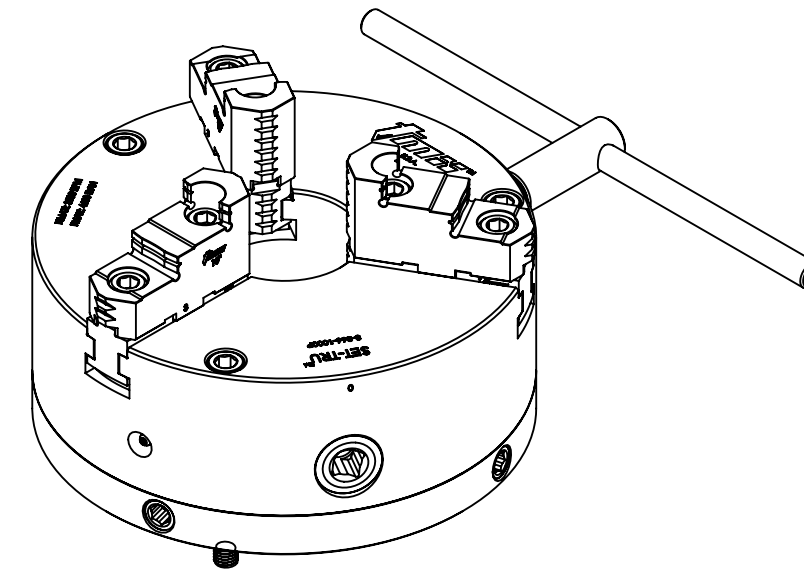

SECTION A-A



MATERIAL:	SEE BOM	NAME:	T. THACH	DATE:	11-11-2024	 TOOLMEX™ SOLE PROPERTY OF TOOLMEX INDUSTRIAL SOLUTIONS	
HARDNESS:	N/A	FINISH:	N/A	DRAWN:	T. THACH		
<u>CONTACT INFORMATION:</u> Toll Free 855-869-2425 Fax 508-653-5110 www.tmxtools.com 34 TALBOT ROAD NORTH BOROUGH, MA 01532 USA				ENG APPR.:	T. THACH		
				MFG APPR.:			
INTERPRET GEOMETRIC TOLERANCING PER: Y1999-2001				Q.A. APPR.:		TITLE	10IN, 3-JAW PLAIN BACK FRONT MOUNT SET-TRU SCROLL CHUCK
				SALES APPR.:		SIZE	DWG. NO. B 3-866-1000P
 THIRD ANGLE PROJECTION				CONFIDENTIAL THIS DRAWING AND THESE SPECIFICATIONS ARE THE SOLE PROPERTY OF TOOLMEX INDUSTRIAL SOLUTIONS, AND SHALL NOT BE REPRODUCED, OR COPIED IN PART OR AS A WHOLE WITHOUT THE EXPRESS WRITTEN PERMISSION OF TOOLMEX INDUSTRIAL SOLUTIONS IS PROHIBITED.		UNITS IN MILLIMETER	
						DO NOT SCALE DRAWING	SHEET 2 OF 3

8 7 6 5 4 3 2 1

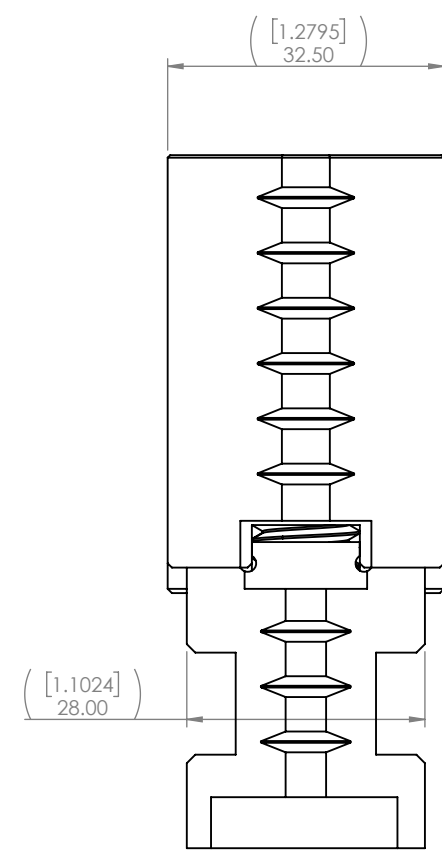
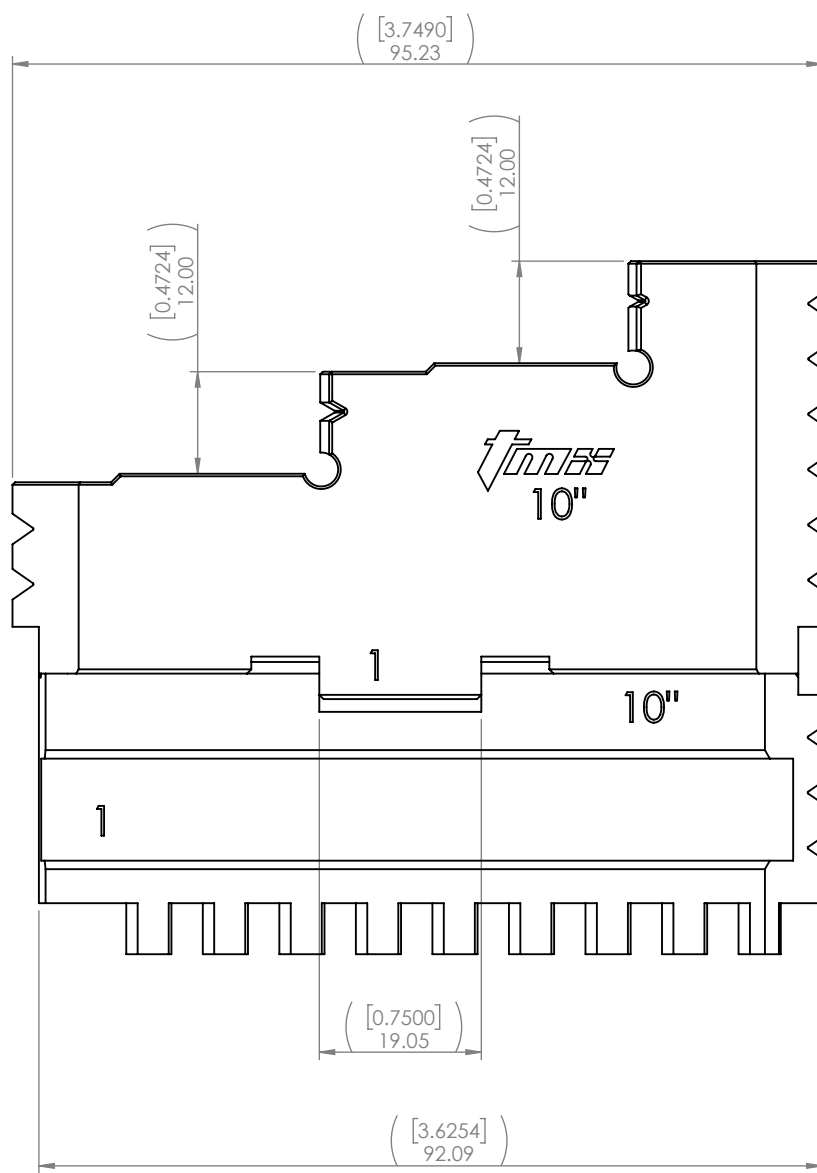
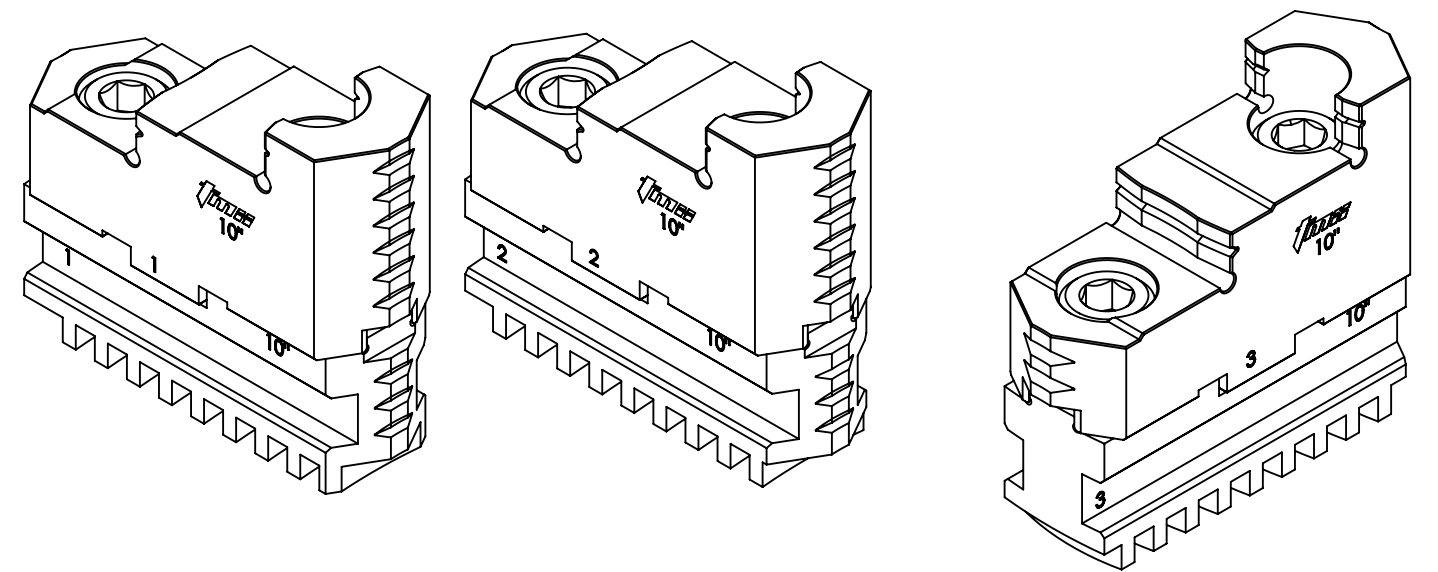
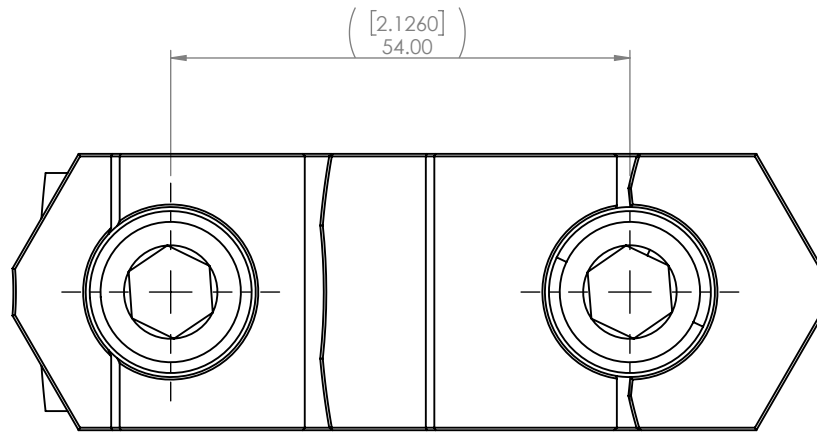

-CLICK ON LINKS BELOW FOR REPLACEMENT PARTS-
[3-883-310P, HARD TOP JAWS, 10IN, 3-JAW 3 PC SET](#)
[3-885-310P, HARD MASTER JAWS, 10IN, 3-JAW 3 PC SET](#)

D
C
B
A

D
C
B
A

8 7 6 5 4 3 2 1

MATERIAL:	SEE BOM	NAME	T. THACH	DATE	11-11-2024
HARDNESS:	N/A	FINISH:	N/A	DRAWN	T. THACH
<p>CONTACT INFORMATION: Toll Free 855-869-2425 Fax 508-653-5110 www.toolmex.com 34 TALBOT ROAD NORTH BOROUGH, MA 01532 USA</p> <p>INTERPRET GEOMETRIC TOLERANCING PER: Y1999-2001</p> <p>THIRD ANGLE PROJECTION</p>			ENG APPR.	T. THACH	11-11-2024
			MFG APPR.		
			Q.A. APPR.		
			SALES APPR.		
<p>TOOLMEX™ SOLE PROPERTY OF TOOLMEX INDUSTRIAL SOLUTIONS</p> <p>TITLE 10IN, 3-JAW PLAIN BACK FRONT MOUNT SET-TRU SCROLL CHUCK</p>			<p>SIZE DWG. NO. REV</p> <p>B 3-866-1000P A</p>		
<p>UNITS IN MILLIMETER</p>			<p>DO NOT SCALE DRAWING SHEET 3 OF 3</p>		

CONFIDENTIAL
 THIS DRAWING AND THESE SPECIFICATIONS ARE THE SOLE PROPERTY OF TOOLMEX INDUSTRIAL SOLUTIONS, AND SHALL NOT BE REPRODUCED, OR COPIED IN PART OR AS A WHOLE WITHOUT THE EXPRESS WRITTEN PERMISSION OF TOOLMEX INDUSTRIAL SOLUTIONS IS PROHIBITED.